

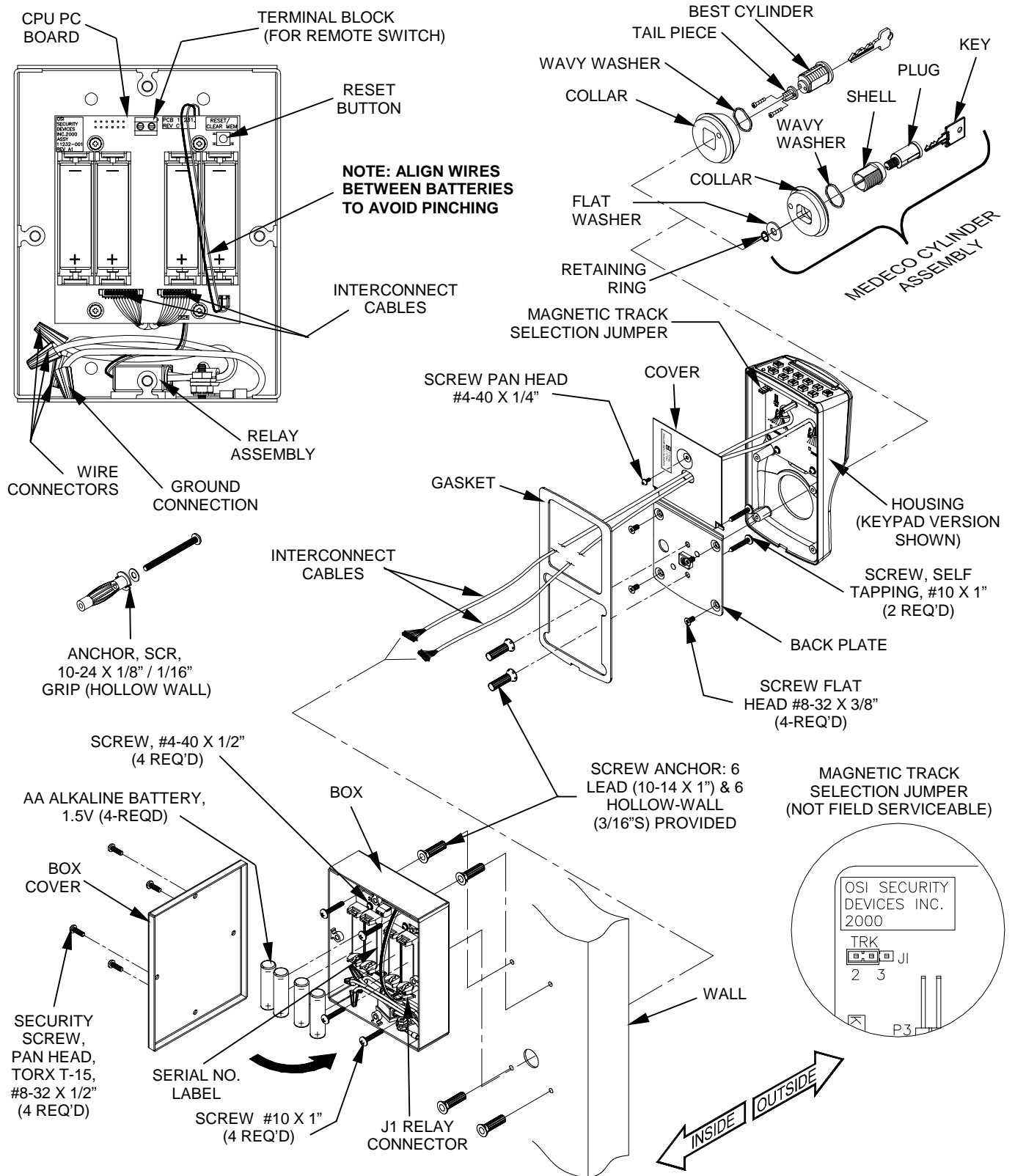

**SECURITY
DEVICES**

**OMNILOCK®
ACCESS CONTROL SYSTEMS**

INSTALLATION INSTRUCTIONS FOR OM2000 SERIES WEATHERIZED WALL MOUNT SYSTEM (WMS)



READ COMPLETE INSTRUCTIONS BEFORE PROCEEDING

SECTION 1: CHECK OPERATION

- Temporarily connect the Interconnect Cables to the connectors on the CPU PC Board.
- If your System has Keypad, proceed as follows, otherwise go to Step c. Verify proper Keypad operation of the System by entering the Default Programmer ID, **1 2 3 4**, at the Keypad. The System will flash green once and the Relay will "click", then, during the open delay it will flash green (5) times. It will then flash red and the relay will "click". If the System malfunctions, go to step d.
- If your System has a Magnetic Card Reader, proceed as follows, otherwise go to Step e. Verify proper operation of the Magnetic Card Reader. A Label on the Housing Assembly Cover indicates the Magnetic Card track, Track 2 or Track 3 that the System is set to read. Select the corresponding Default Programmer ID Card furnished with the Administrator's Guide. Insert and remove it with the magnetic stripe on the card aligned with the "V" mark by the card slot. The lights will flash as in the previous step. If the System malfunctions, go to step d, otherwise go to step e.
- If the system malfunctions, proceed as follows: Check for proper orientation and seating of the Batteries and Relay Connector. Remove the Housing Assembly Cover and Check that the Track Selection Jumper is in the desired position. Also ensure that the wires are not pinched. Reset the electronics by pressing and holding the Reset Button on the CPU PC approximately three (3) seconds, until the light flashes green. The System will go through a self-test cycle, and then flash green five (5) times. (Any red flashes indicate relay or PC Board problems.) Replace the Cover. Now repeat the verification process.
- Disconnect the Interconnect Cables from the CPU PC Board.

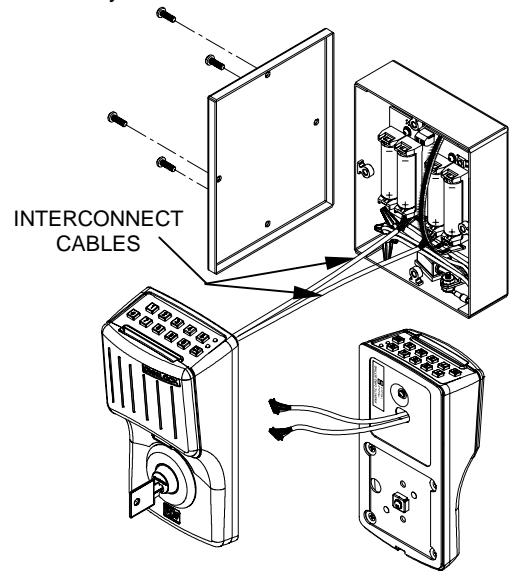

NOTE: MAGNETIC CARD TRACK SETTING IS NOT FIELD SERVICEABLE.

SECTION 2: GENERAL INFORMATION

Electrical Installation: Install in accordance with local and national electrical codes.

Static Electricity Protection: Since the Wall Mount System controller controls external circuits; particular care must be taken to ensure that static electrical discharges will not cause difficulties in operation. A typical source of static discharge is a user who accumulates a charge while walking across a rug, then upon reaching for the keyboard, causes a spark to jump from the hand to the keyboard. The basic principle is that all devices connected with the system should be electrically connected to a common ground. This means that the case of the Wall Mount System (green/yellow wire) should be connected to the chassis of the door strike or other device, which it operates. In addition, if possible, one of the device power supply leads should be grounded to the common ground. (Refer to Diagram 1) A number 18 AWG (#10 MWG) or larger copper wire is recommended to connect the components together and to a building ground if available. The equipment-grounding conductor (bare wire or green) normally in an electrical outlet box (or a metal box itself) is recommended for grounding.

Remote Operation: The Wall Mount System can be activated through a remote switch (secretary's switch). When properly wired, momentarily pressing the remote switch will cause the System to cycle and the event will be recorded in the Audit Log. (Refer to Section 9). If the Switch is held closed the cycle time will be extended.

CONNECTIONS			
COMMON	NORMALLY OPEN CONTACT (FAIL SECURE)	NORMALLY CLOSED CONTACT (FAIL SECURE)	GROUND
BLACK WIRE	WHITE WIRE	ORANGE WIRE	GREEN/YELLOW WIRE

NOTES: (1): POWER SUPPLY: 24 VOLTS (RMS OR DC) NOMINAL OR LESS.

(2): DOOR DEVICE CURRENT NOT TO EXCEED 5A.

(3): CONNECT ONE OF THE POWER SUPPLY OUTPUT LEADS TO THE EQUIPMENT GROUND IF NOT ALREADY CONNECTED.

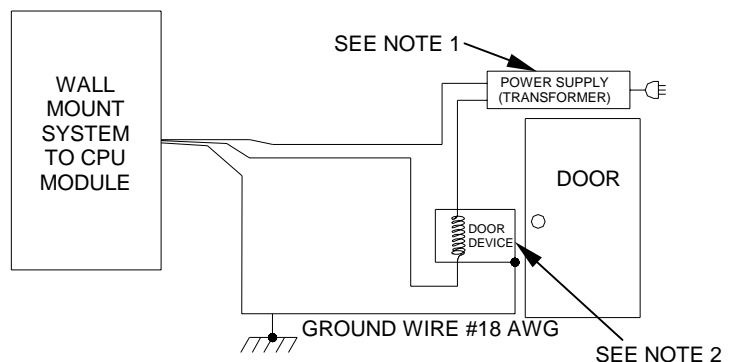

Wall Mount System Wiring Diagram 1

SECTION 3: PREPARE THE WALL

- Determine the locations for mounting the Housing Assembly and CPU Module. Consider the route for wires between the device to be controlled and the CPU Module. Also consider wheelchair access.
- Place the Mounting Templates for the Housing Assembly and the CPU Module in the desired locations, ensure that the top edge is horizontal and mark the centers for the holes.
- Drill the holes as indicated on the Template. Note that the hole size for Mounting Screws depends upon the type of wall material and the type Screw Anchors used. Screw Anchors are provided.
- Install the Screw Anchors if required.

SECTION 4: INSTALL WIRING

- Ensure that the Power Supply for the Device is turned off.
- Route the Power Supply Wire, the Device Wire and the Device Ground Wire to the CPU Module Wire Access Hole in the Wall. Allow the Wires to extend approximately 4" from the Wall.
- If a Remote Switch is to be installed, route a twisted pair of wires from the switch location through the wire access hole in the wall. (Refer to Section 9.)

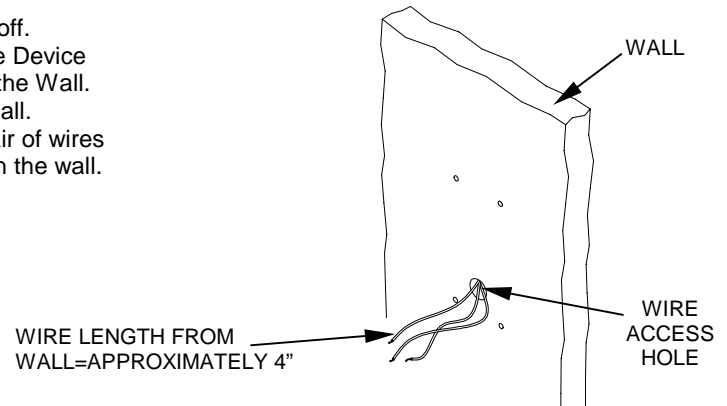

SECTION 5: INSTALL THE WALL MOUNT SYSTEM

5-1 INSTALL THE HOUSING ASSEMBLY

- Insert the Key into the Cylinder Assembly and rotate the Key counterclockwise until the Cylinder Assembly can be removed from the unit.
- Guide the Interconnect Cables through the hole in the wall to the CPU Module location.
- Place the Housing Assembly against the wall and secure with the Mounting Screws.

5-2 INSTALL THE CPU MODULE

- Pass the Interconnecting Cables and other wires protruding from the wall through the hole in the CPU Module Bracket. Align the Bracket with the mounting holes in the Wall and secure the Bracket with the Screws.
- Connect Cables from the Housing Assembly to the bottom of the CPU PC board as shown on Page 1 (One 12 Pin and One 10 Pin Connector).
- Connect the Wires, using the Screw-On Wire Connectors as shown below in Diagram 2 for the function desired. Tighten the Connector on the unused Wire.
- If a Remote Switch is being installed connect the wires from the Remote Switch to the Terminal Block on the CPU PC Board. (Refer to Section 9.)

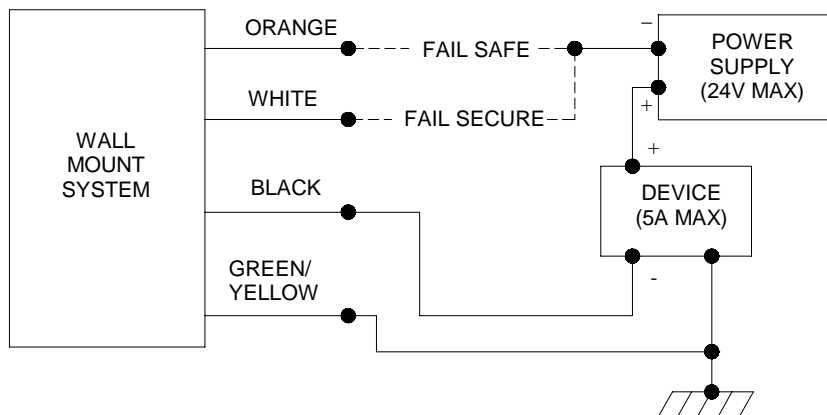

Wall Mount System Wiring Diagram 2

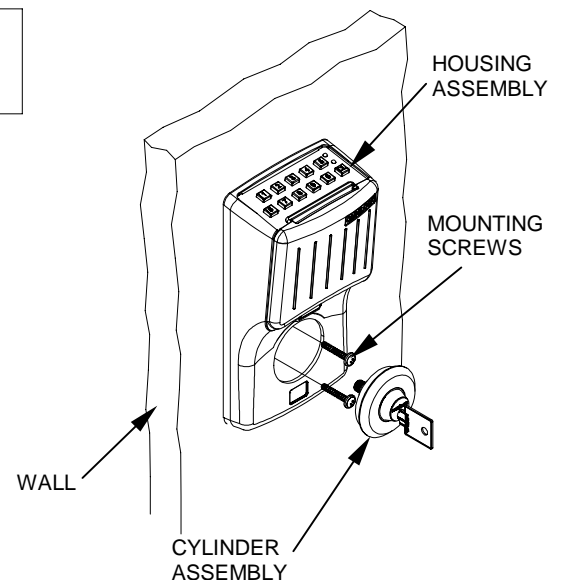

SECTION 6: PRE-TEST THE INSTALLATION

- Turn on the power to the Device and determine if it is in the proper state. If it is not in the proper state, check the Power Supply and Wiring.
- Enter the Default Programmer ID, **1 2 3 4**, at the Keypad or use the Default Programmer ID Card if your System does not have a keypad. The green light will flash once (1) and the Device will change state, then, during the open delay, it will flash green five (5) times. After approximately five (5) seconds, the red light will flash and the Device will return to its original state.
- If a Remote Switch has been installed, momentarily press the switch. The green light will flash once (1) and the Device will change state. After approximately five (5) seconds, the red light will flash and the Device will return to its original state.

SECTION 7: COMPLETE THE INSTALLATION

- Place the wires inside the CPU Module so that the Cover will not pinch the wires.
- Connect the Ground Wire from the CPU Module Cover to the CPU Bracket Ground Connection. Place the Cover over the Bracket and secure with the Security Screws.
- Insert the Cylinder Assembly into the Housing Assembly so that the hole in the Collar engages the Stud in the Back Plate. Rotate the Key Clockwise until the Cylinder Assembly is snug. For the Medeco Cylinder, the Key may be removed in any vertical or horizontal position. For Best Cylinders the Key may be removed in only one vertical position.
- Enter the Default Programmer ID, **1 2 3 4**, or use the Default Programmer ID Card, and check for proper operation of the System.
- If a Remote Switch has been installed, check for proper operation of the System.
- Record the Key identification number and keep it in a safe place so that duplicate Keys can be ordered if required. For Medeco Cylinders, keys must be ordered through OSI Security Devices.

SECTION 8: PROGRAM THE SYSTEM

IMPORTANT: To avoid unauthorized access, it is important to program a new Programmer ID.

Refer to the OMNILOCK Administrator's Guide for programming instructions.

If the System has been installed before the required programming information is available and the System has a keypad, the Access level may be set to unlocked as follows:

- Enter the Default Manager ID, **2 2 2 2**, at the Keypad, the green light will flash.
- Press **2**, the green light will flash.
- Press and hold the **CL** key. The green light will flash four times. (The light will flash once when the **CL** key is first pressed, continue to hold the key until the light flashes again, this is the start of a 3 Flash Sequence.)
- The Device will remain in the Unlocked mode.

SECTION 9: REMOTE SWITCH

- Remote operation of the System may be accomplished by a momentary Switch closure. This may be desirable for someone monitoring a protected entrance, such as a receptionist. Momentarily pressing the Switch will cause the System to go through a normal unlock and lock sequence. If the Switch is held closed, the open time will be extended.
- For installation refer to Step 4c and Step 5-2d.

