

INSTALLATION INSTRUCTIONS FOR OM100, OM300, AND OM500 SERIES NON-WEATHERIZED, WALL MOUNT SYSTEMS (WMS)

WARNING: THIS PRODUCT IS NOT WARRANTED FOR OUTDOORS USE!

OPTIONAL BEST CYLINDER ASSEMBLY

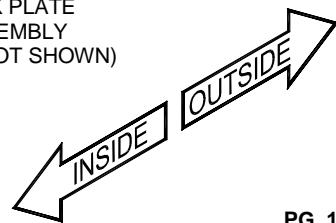
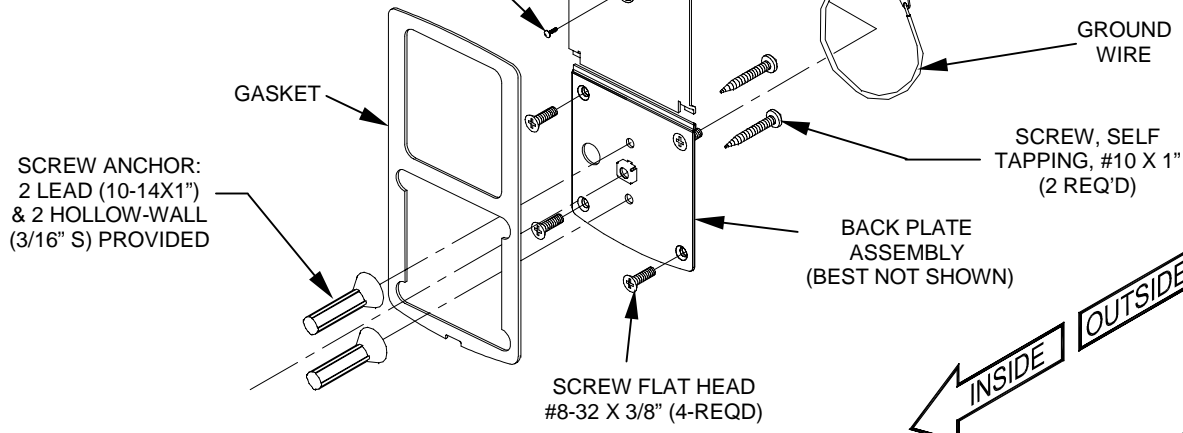
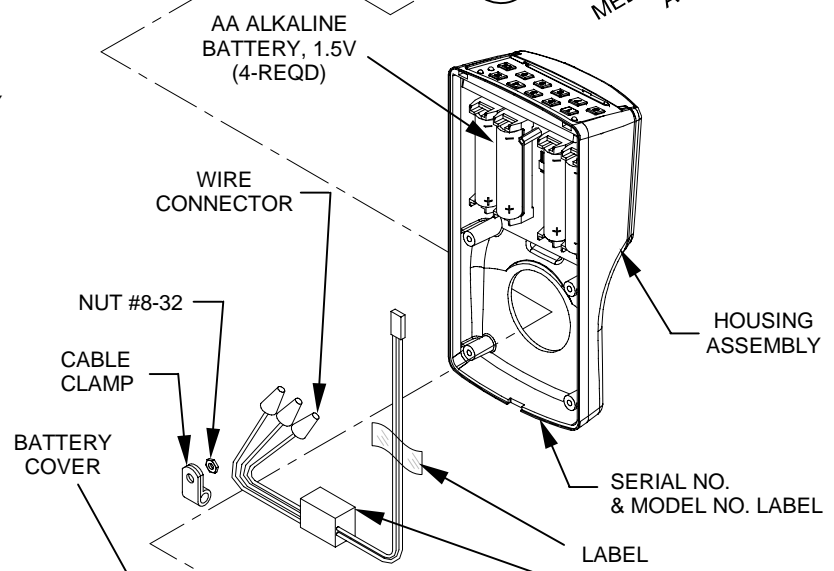
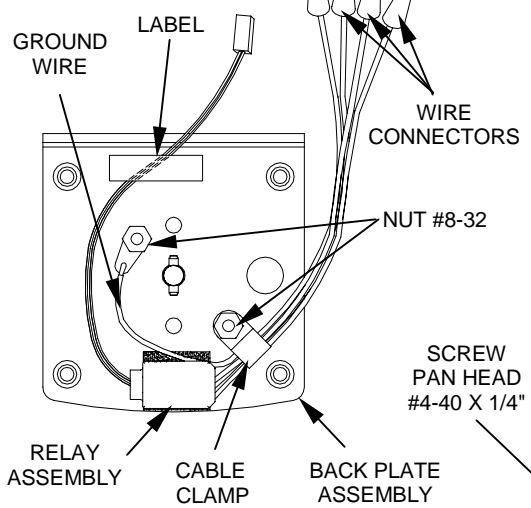
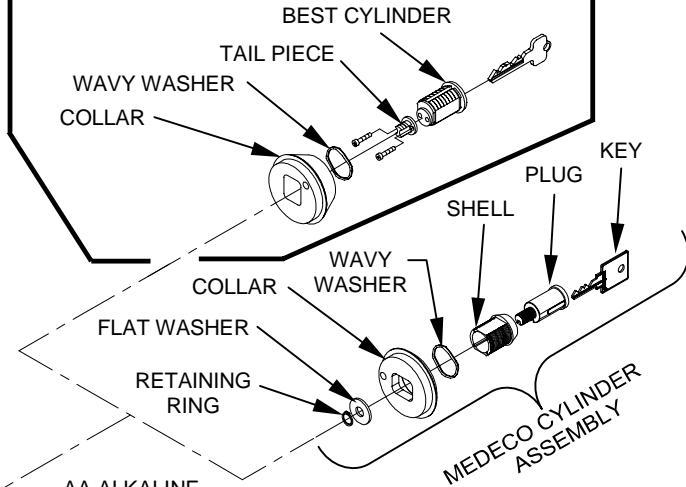
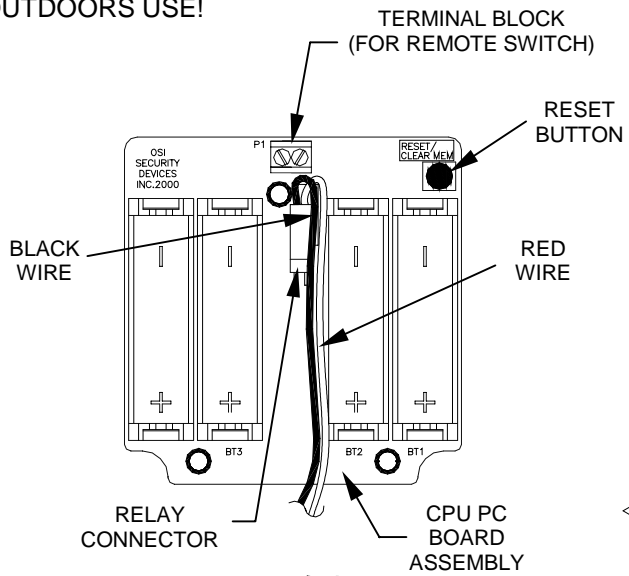

SECTION 1: CHECK OPERATION

- a. Verify proper operation of the System by entering the Default Master Code **5 0 1 1 2 3 4**. The System will flash three times to indicate the Battery level and the Relay will “click”. After a delay of approximately 5 seconds, it will flash red and the Relay will “click”.
- b. Verify communication with the **WP4000** Printer.
 1. Turn on the Printer and Position it over the Keypad so that the Infrared Port of the Printer is aligned over the Infrared Port of the System.
 2. Enter the Default Master Code **5 0 1 1 2 3 4** at the Keyboard and then enter **99**.
 3. The Printer will print some System data and then present a menu of choices.
 4. Enter **0** (END) at the Keypad. The System will flash red and re-locked.
- c. If the system malfunctions, remove the Battery Cover and check for proper orientation and seating of the Batteries and Relay Connector. Also ensure that the wires are not pinched. Reset the electronics by pressing and holding the Reset Button on the circuit board until the light on the Keypad flashes green, approximately three to five seconds. The System will go through a self-test and flash green 5 times. Any red flash indicates an electronics or motor problem. If all flashes are green, repeat Steps a, and b.

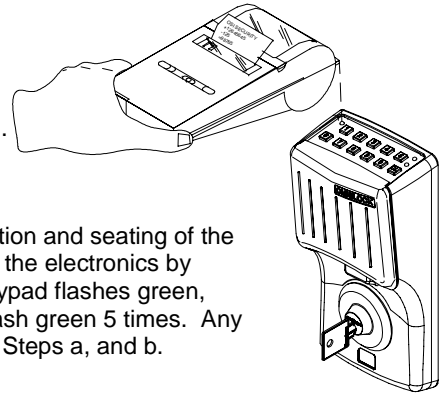

SECTION 2: GENERAL INFORMATION

Electrical Installation: Install in accordance with local and national electrical codes.

Static Electricity Protection: Since the Wall Mount System controller controls external circuits; particular care must be taken to ensure that static electrical discharges will not cause difficulties in operation.

A typical source of static discharge is a user who accumulates a charge while walking across a rug, then upon reaching for the keyboard, causes a spark to jump from the hand to the keyboard. The basic principle is that all devices connected with the system should be electrically connected to a common ground. This means that the case of the Wall Mount System (green/yellow wire) should be connected to the chassis of the door strike or other device that it operates. In addition, if possible, one of the device power supply leads should be grounded to the common ground. (Refer to Diagram 1) A number 18 AWG (#10 MWG) or larger copper wire is recommended to connect the components together and to a building ground if available. The equipment-grounding conductor (bare wire or green) normally in an electrical outlet box (or a metal box itself) is recommended for grounding.

Remote Operation: The Wall Mount System can be activated through a remote switch (secretary's switch). When properly wired, momentarily pressing the remote switch will cause the System to cycle and the event will be recorded in the Audit Log. (Refer to Section 9).

CONNECTIONS			
COMMON	NORMALLY OPEN CONTACT (FAIL SECURE)	NORMALLY CLOSED CONTACT (FAIL SAFE)	COMMON
BLACK WIRE	WHITE WIRE	ORANGE WIRE	GREEN/YELLOW WIRE

NOTES: (1): POWER SUPPLY: 24 VOLTS (RMS OR DC) NOMINAL OR LESS.

(2): DOOR DEVICE CURRENT NOT TO EXCEED 5A.

(3): CONNECT ONE OF THE POWER SUPPLY OUTPUT LEADS TO THE EQUIPMENT GROUND IF NOT ALREADY CONNECTED.

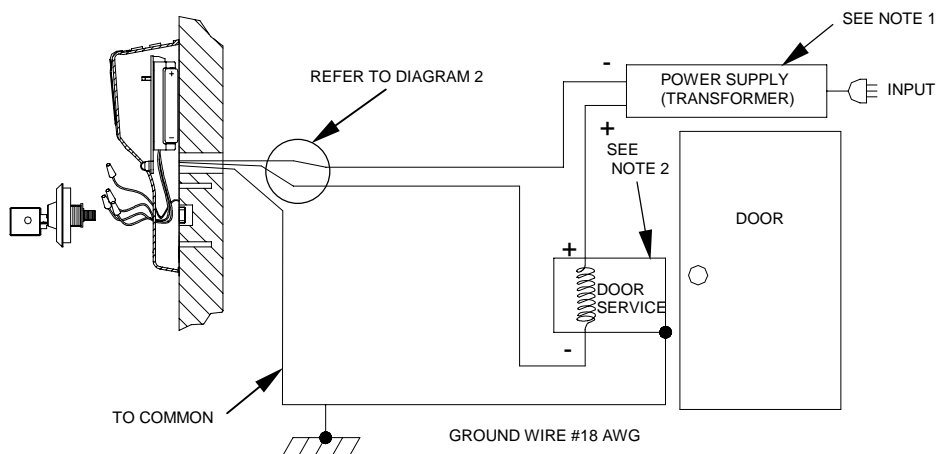

(EXAMPLE) Wall Mount System Wiring Diagram 1

SECTION 3: PREPARE THE WALL

- Determine the location for mounting the Unit. Consider the route for wires between the device to be controlled and the Unit. Also consider wheelchair access.
- Place the Mounting Template in the desired location, ensure that the top edge is horizontal and mark the centers for the four holes.
- Drill the holes as indicated on the Template. Note that the hole size for Mounting Screws depends upon the type of wall material and the type Screw Anchors used. Hollow Wall Anchors and Lead Anchors are provided.
- Install the Screw Anchors if required.

SECTION 4: INSTALL WIRING

- Ensure that the Power Supply for the Device is turned off.
- Route the Power Supply Wire, the Device Wire and the Device Ground Wire to the Wire Access Hole in the Wall. Allow the Wires to extend approximately 4" from the Wall.
- If a Remote Switch is to be installed, route a twisted pair of wires from the switch location to the wire access hole in the wall. (Refer to Section 9).

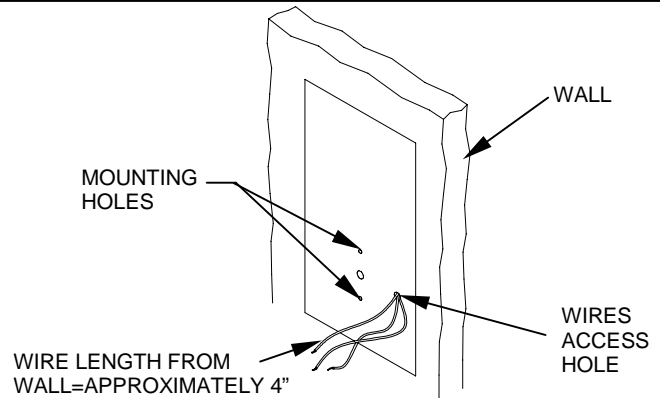

SECTION 5: INSTALL THE WALL MOUNT SYSTEM

- Insert the Key into the Cylinder Assembly and rotate the Key counterclockwise until the Cylinder Assembly can be removed from the unit.
- Guide the ends of the Wires from inside the unit out through the hole.
- If a Remote Switch is being installed, proceed as follows, otherwise go to Section 5d.
 - Remove the Battery Cover.
 - Connect two (2) wires approximately nine (9) inches long to the Remote Switch Terminal Block on the PC Board and route the wires out through the hole in the front of the module. (Refer to Section 9).
 - Replace the Battery Cover.
- Guide the Wires from the Wall through the hole in the Back Plate and out through the hole in front of the Unit.
- Place the Unit against the Wall and secure with the Mounting Screws.
- Connect the Wires, using the Screw-On Wire Connectors as shown below for the function desired. Tighten the Connector on the unused Wire.
- If a Remote Switch is being installed connect the wires from the Remote Switch to the wires from the Terminal Block.

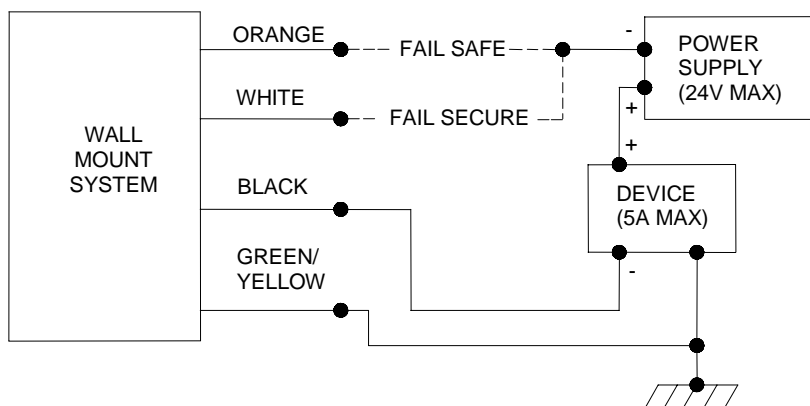

Wall Mount System Wiring Diagram 2

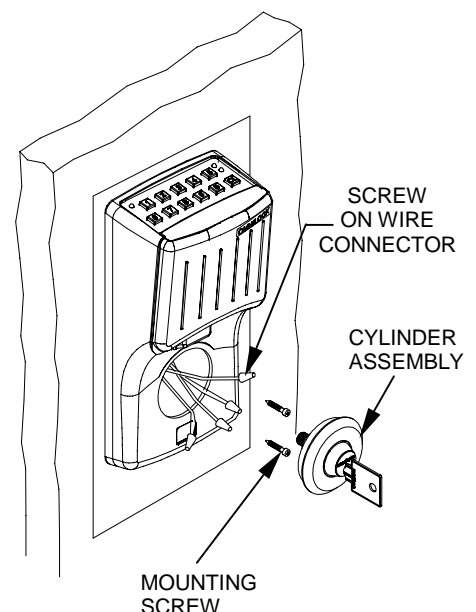

SECTION 6: PRE-TEST THE INSTALLATION

- Turn on the power to the Device and determine if it is in the proper state. If it is not in the proper state, check the Power Supply and Wiring.
- Enter the Default Master Code, **5 0 1 1 2 3 4**, at the Keyboard. The green light will flash three times to indicate the Battery level and the Device will change state. After approximately five (5) seconds, the red light will flash and the Device will return to its original state.
- If a Remote Switch has been installed, momentarily press the switch. The green light will flash once (1) and the Device will change state. After approximately five (5) seconds, the red light will flash and the Device will return to its original state.

SECTION 7: COMPLETE THE INSTALLATION

- Place the wires inside the Unit so that they are clear of the hole.
- Insert the Cylinder Assembly into the Unit so that the hole in the Collar engages the Stud in the Back Plate. Rotate the Key Clockwise until the Cylinder Assembly is snug. For Medeco Cylinders, the Key may be removed in any vertical or horizontal position. For Best Cylinders, the Key may be removed in only one vertical position.
- Enter the Default Master Code, **5 0 1 1 2 3 4**, and check for proper operation of the Device.
- If a Remote Switch has been installed, check for proper operation of the Device.
- Record the Key identification number and keep it in a safe place so that duplicate Keys can be ordered if required. For Medeco Cylinders, Keys must be ordered through OSI Security Devices.

SECTION 8: PROGRAM THE SYSTEM

IMPORTANT: To avoid unauthorized access, it is important to program a new Master Code.

For Programming instructions refer to the Quick Reference Guide shipped with this product or to the OMNILOCK User Guide which may be ordered by calling Customer Service at 619-628-1000 or it may be downloaded from our website <http://www.omnilock.com/files/om135man.pdf>

SECTION 9: REMOTE SWITCH

- Remote operation of the System may be accomplished by a momentary Switch closure. This may be desirable for someone monitoring a protected entrance, such as a receptionist. Momentarily pressing the Switch will cause the System to go through a normal unlock and lock sequence. If the Switch is held closed, the open time will be extended.
- For installation refer to step 4c and section 5.

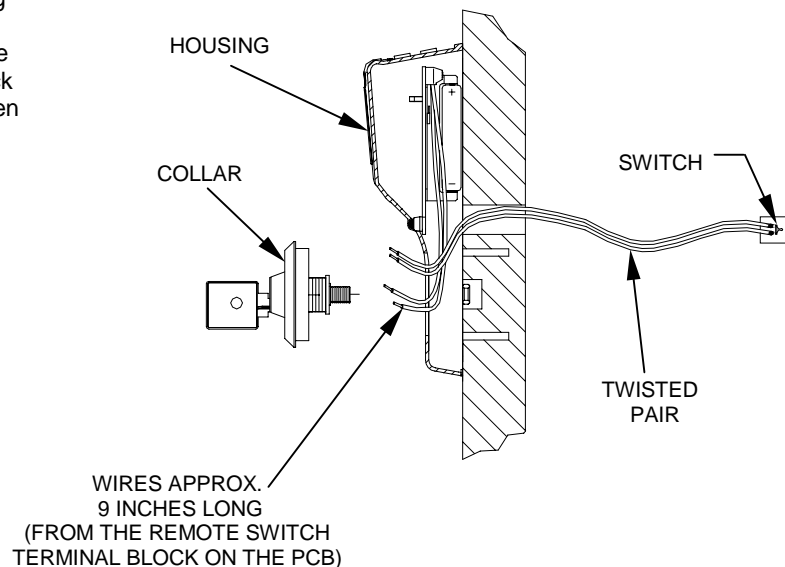

INSTALLER NOTES: Leave these instructions and other documents with the User.