



**SECURITY
DEVICES**

**OMNILOCK[®]
ACCESS CONTROL SYSTEMS**

INSTALLATION INSTRUCTIONS FOR QP2000 SERIES NON-WEATHERIZED QUICK ADAPTER USING SCHLAGE[®] D-SERIES CYLINDRICAL LOCK (LEVER)

WARNING: THIS PRODUCT IS NOT **WARRANTED** FOR OUTDOOR USE!

NOTE: A DOOR-CLOSER IS HIGHLY RECOMMENDED FOR USE WITH THIS PRODUCT.

WARNING: METAL INSERT MUST BE INSTALLED FOR LOCK TO WORK PROPERLY WITH OLD STYLE DRIVER.

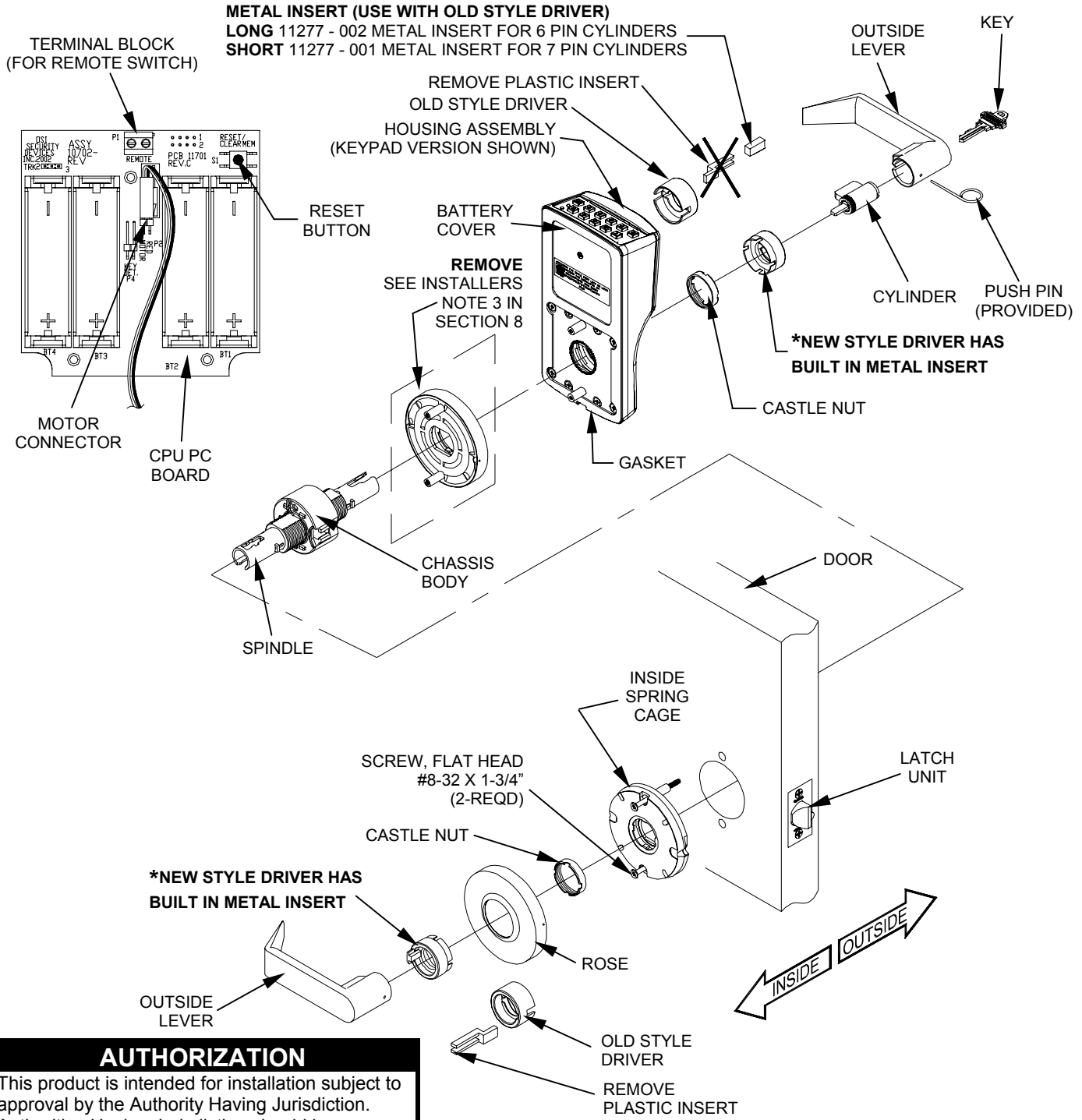

AUTHORIZATION

This product is intended for installation subject to approval by the Authority Having Jurisdiction. Authorities Having Jurisdiction should be consulted before installation.

SECTION 1: LOCK COMPATIBILITY

1-1 LEVER LOCKS ONLY

The QP2000 is designed for use **ONLY** with the Schlage D-Series LEVER locks listed in the Table below. USE OF ANY OTHER LOCK VOIDS ALL WARRANTIES EXPRESSED OR IMPLIED.

INTERCHANGEABLE CORE LOCKS

Interchangeable Core Key Cylinders may be used only if the lockset has a Driver with a metal key (Schlage "new" style Driver) for the Outside Lever.

QP2000 FUNCTION AND FAILURE RECOVERY

The QP2000 performs the locking/unlocking function by locking the Outside Lever and Spindle until a valid ID is entered. Should the QP2000 fail for any reason (dead batteries, etc.) the Key is used to bypass the QP2000. This feature is important when the QP2000 is mounted on a door having sole access to a room. Some D-series models, as indicated in the Table below, allow the Key Cylinder to directly retract the Latch for access. Models that do not allow the Key Cylinder to directly retract the latch require removing the Lever, disengaging the Driver and turning the Spindle to gain access.

SCHLAGE D-SERIES LEVER LOCK (SEE NOTE 2)	LOCK DESCRIPTION	ANSI LOCK FUNCTION	LOCK REQUIRES MODIFICATION	EMERGENCY KEY BYPASS		REMARK
				WITHOUT REMOVING LEVER	REQUIRES REMOVING LEVER	
D50	ENTRANCE/OFFICE	F82			X	
D53	ENTRANCE	F109		X		
D60	VESTIBULE	F88		X		
D66	STORE	F91			X	SEE NOTE 1
D70	CLASSROOM	F84			X	
D73	CORRIDOR	F90		X		
D80	STOREROOM	F86	X	X		
D82	INSTITUTION	F87	X	X		SEE NOTE 1 & 3

NOTE 1:

CAUTION: DOUBLE CYLINDER LOCKS ON RESIDENCES AND ANY DOOR IN ANY STRUCTURE, WHICH IS USED FOR EGRESS, ARE A LIFE SAFETY HAZARD IN TIMES OF EMERGENCY AND THEIR USE IS NOT RECOMMENDED. INSTALLATION SHOULD BE IN ACCORDANCE WITH EXISTING CODES.

NOTE 2:

Locks with Interchangeable core (I.C.) Levers must have the Schlage new style Driver with integral lug to be used with the QP2000.

NOTE 3:

SERIES D82 LOCKS require a Mounting Plate Kit and 2 each QP2000. This System will work on a 1-3/4" thick door using a standard Schlage Series D82 Lock. For doors thicker than 1-3/4" the Lock must be designed to fit a door 1/4" thicker than the door in which it is to be mounted, thus a 2" thick door requires a lock designed for a 2-1/4" thick door.

MOUNTING PLATE KIT PART #	QA HOUSING FINISH
11842-001	GRAY
11842-002	BLACK
11842-003	SATIN CHROME

1-2 LOCK SOURCE

- a. If the Lock to be used with the QP2000 is currently mounted on a door:
 1. Remove the Lock from the door.
 2. Remove the Outside Lever, Driver, Castle Nut and Spring Cassette.
- b. If the Lock to be used with the QP2000 is a new installation:
 1. Remove the Levers, Drivers, Castle Nuts and Spring Cassettes.

DOOR THICKNESS RANGE	DISTANCE "D"
1-3/4" TO 2"	7/8"
2" TO 2-1/4"	1"
2-1/4" TO 2-1/2"	1-1/8"
2-1/2" TO 2-3/4"	1-1/4"
2-3/4" TO 3"	1-3/8"

1-3 VERIFY LOCK COMPATIBILITY

Verify the Lock is designed for the door thickness in which it is to be installed, see table. The QP2000 will NOT work if the lock is installed in a door of the wrong thickness. The standard door thickness range for Schlage D-Series Locks when assembled with the QP2000 is 1-3/4" to 2". Any thicker door requires a lock designed specifically for that thickness of door. (Contact a Schlage distributor for ordering information.) For Series D82 Locks refer to the Notes in Step 1-1.

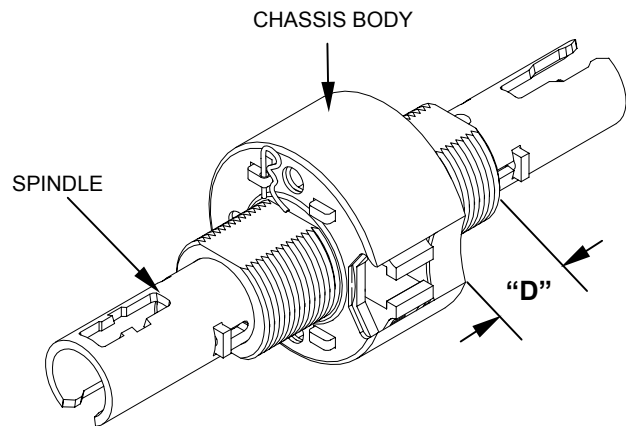

SECTION 2: CHECK OPERATION

- a. Temporarily Install the Lock Driver into the QP2000 so that the slots of the driver engage the lugs in the QP2000.
- b. Verify proper operation of the System using the Default Programmer ID Proximity Card. Momentarily place the center of the Proximity Card (Included in the OMNILOCK Administrator's Kit) over the recess in the front of the QP2000. The QP2000 will flash green once and unlock, then, during the Open Delay Time, it will flash green five times. The QP2000 will flash red and lock. While unlocked, check for proper operation of the lock.
- c. If your System has a Keypad Proceed as follows, otherwise go to Step d: Verify proper operation of the System using the Keypad. Enter the Default Programmer ID, **1 2 3 4**, at the Keypad. The Lights will flash as in the previous step.
- d. Remove Lever and Driver.
- f. If the System malfunctions remove the Battery Cover and check for proper orientation and seating of the Batteries, Motor Connector and Key Detection Connector. Ensure that the wires are not pinched. Reset the electronics by pressing and holding the Reset Button on the circuit board until the light flashes green, approximately three seconds. The System will go through a self-test and flash green 5 times. Any red flash indicates an electronics or motor problem. Repeat the verification process if all flashes are green.

SECTION 3: LOCK MODIFICATION

- a. If you are using a Schlage Series D80 or D82 Lock proceed as follows, otherwise, go to Section 4.
- b. Schlage Series D80 and D82 Locks
 - Modification by a qualified locksmith is required before they can be used with the QP2000. The Locked Spindles of these Locks normally do not rotate and access is by key only. This modification permanently unlocks the Locked Spindles so they can rotate to allow the QP2000 to control access.
 - There are two ways this modification can be performed. The easiest way is to replace the Lock's internal Key Cam Assembly with OSI Key Cam P/N 10262. The alternate way (but just as effective) is to modify the Lock's Key Cam Assembly by removing its internal parts. Both methods are as follows:

METHOD #1: Replace the Key Cam Assembly

1. Disassemble the Lock as shown below.
2. Remove the Key Cam Assembly and replace it with OSI Key Cam P/N 10262. Retain the Key Cam Assembly in a safe place should it be decided to restore the lock to its original condition.
3. Reassemble the Lock.
4. Go to Section 4.

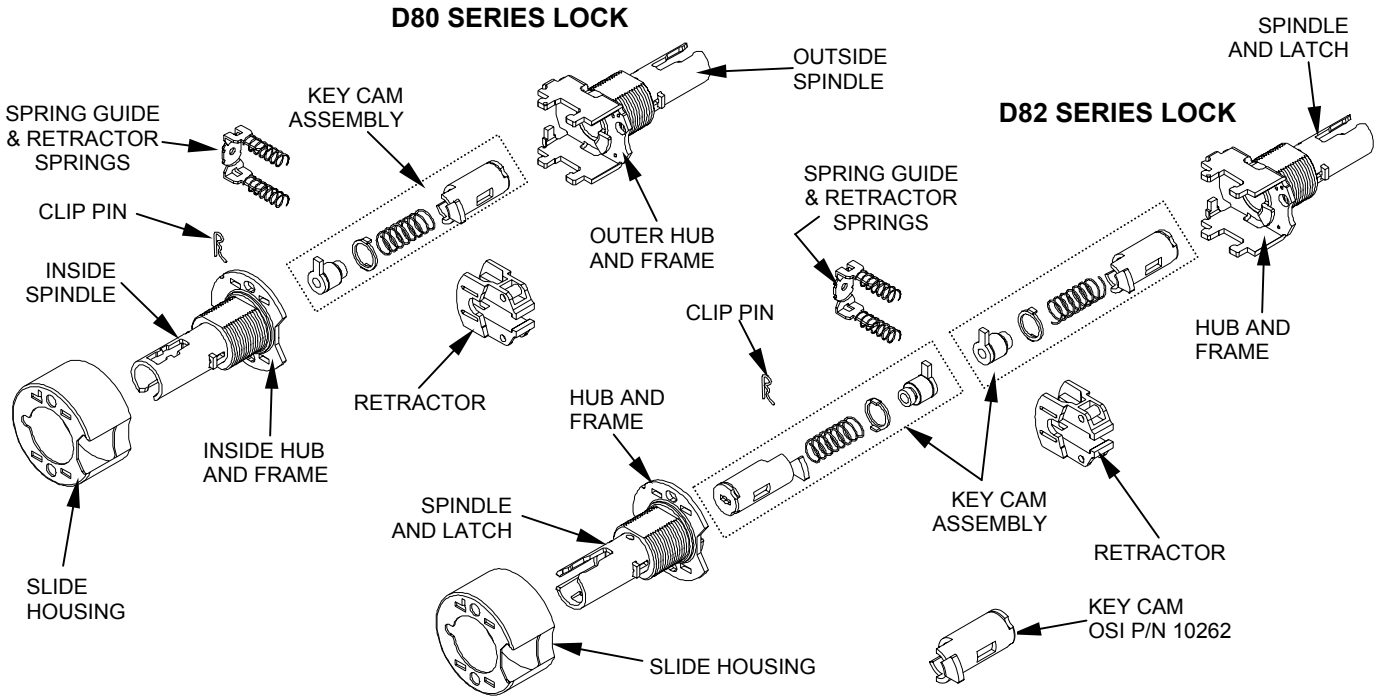

METHOD #2: Modify the Key Cam Assembly

1. Disassemble the Lock as shown above.
2. Remove the Key Cam Assembly.
3. Relieve the Spring pressure on the Locking Plug Retainer by compressing the Spring with a small tool. Use care not to deform or damage the Key Cam. (See illustration below).
4. Press the Retainer toward its bent tab and rotate the tab side of the Retainer toward the Spring to release the Locking Plug.
5. The Locking Plug, Retainer and Spring are not required. However, retain them in a safe place should it be decided to restore the Lock to its original condition.
6. Insert the Key Cam into the Outside Spindle of the D80 Series Lock and in both Spindles of the D82 Series Lock.
7. Reassemble the Lock.
8. Go to Section 4.



SECTION 4: PREP THE DOOR

- The QP2000 does not require any additional modifications to the door except when using Series D82 Locks. **For Series D82 Locks see the instructions that come with the Mounting Plate Kit. The following Sections of this instruction do not apply to Series D82 Locks.**
- If the Lock is to be installed on a new door, prep the door and frame in accordance with the instructions that came with the Lock, and install the Latch and Strike. **Accurate door preparation is required for the Lock to function properly.**

SECTION 5: INSTALL THE QP2000/LOCK ASSEMBLY

5-1 PREP LOCK AND QP2000 FOR INSTALLATION

- Orient the Lock for the proper hand and insert the Outside Spindle and Hub through the back of the QP2000. **(For Series D82 Locks see the Instruction that came with the Mounting Plate Kit).**
- Install the Castle Nut and adjust to about 1/4" past the end of the Chassis threads for a 1-3/4" thick door or adjust to about 1/8" for a 2" door using the Installation Tool that came with the Lock.
- With the Castle Nut seated against the Back plate of the QP2000, set the center of the Retractor to be 1/2 the door thickness from the edge of the QP2000.

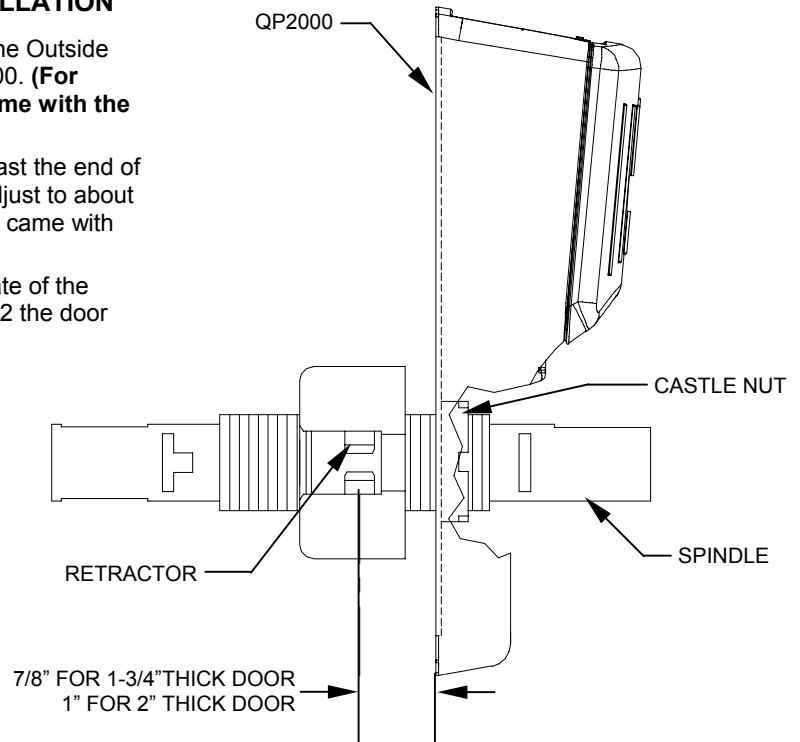

5-2 RETRACTOR AND LATCH ENGAGEMENT

Install the Assembly on the outside of the door. The Slide Housing must engage the Latch Unit Prongs as shown. The Lock Body Retractor must engage the Latch Unit Tail piece.

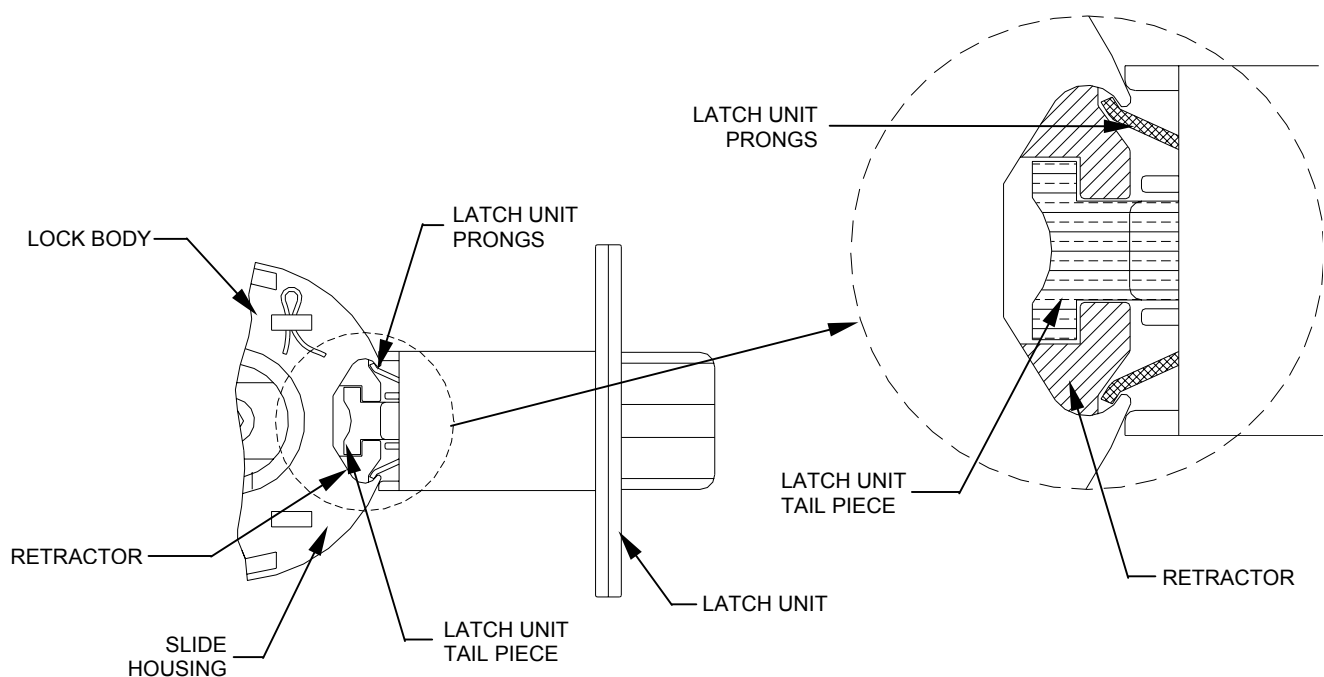

5-3 INSTALL LOCK MOUNTING HARDWARE

- Hold the Lock and QP2000 in place.
- Put the Spring Cage into position over the Inside Spindle.
- Start the Castle Nut on the threads of the Chassis. Ensure the QP2000 is parallel to the edge of the door and while holding the Unit in position, place the Installation Tool onto the Castle Nut and tighten. When you hear the ratcheting sound, continue to tighten until the Castle Nut is tight against the Spring Cage.
- Insert and tighten the Mounting Screws.
- Maximum length is equal to the door thickness plus 1/8".
- Retighten the Castle Nuts with the installation tool and set the length of thread extending beyond the Castle Nuts to be equal when the Castle Nuts are tight.
- Install the Inside Rose. Align the dimples on the Rose with the grooves in the Spring Cage. Place the Rose against the Door and rotate clockwise until the dimples snap into the slots next to the grooves.

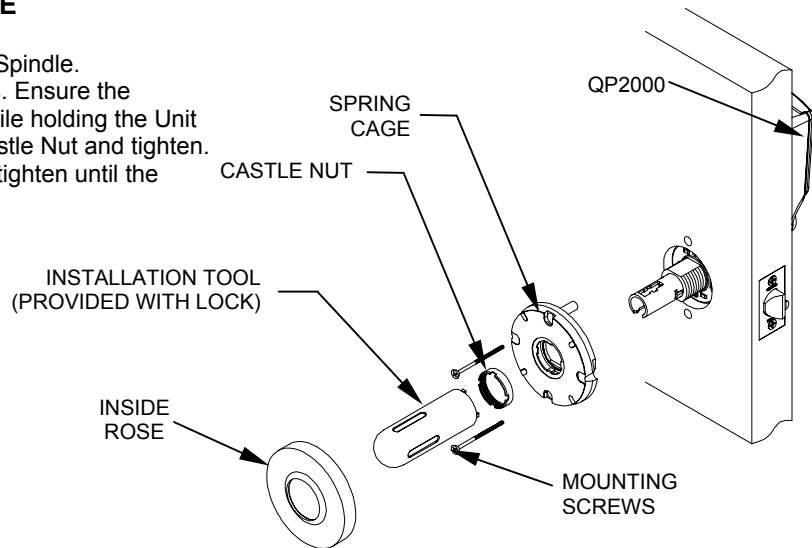

5-4 INSTALL INSIDE LEVER AND DRIVER

- Install the Driver onto the Lever. Some Lock models use a Plastic Insert between the Lever and Driver. Use care to install the Plastic Insert if provided with the Lock as the Lock will not function properly without it. If the Lever has a plastic Insert it must engage the slot in the Driver. If the Lever does not have a Plastic Insert, engage the Slot in the Lever with the Lug on the Driver.

WARNING: The Plastic Insert should only be used on the inside (unlocked side) of the door.

- Slide the Lever and Driver onto the Spindle. Push the Lever completely into place. Pull on the Lever to make sure that the Lever Catch is fully engaged.
- Binding of the Inside Driver is an Indication of incorrect installation or door preparation and must be corrected for proper operation of the Lock.

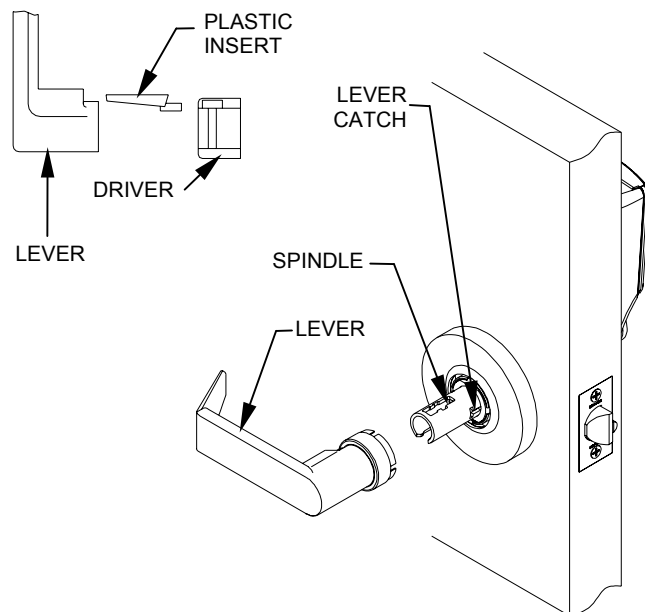

5-5 SET THE LOCK TO THE FULLY LOCKED POSITION

For D50, D66, and D70 Series Locks, insert the Key Cylinder and Key into the Outside Spindle and turn the Key counterclockwise until it stops. Remove the Key Cylinder and Key, then remove the Key from the Key Cylinder.

5-6 INSTALL THE OUTSIDE LEVER

Schlage provides two different kinds of Drivers. The first (and older style) uses a Plastic Insert between the Lever and Driver. The second style has no Plastic Insert. Instead, the Driver has an integral lug that fits directly into the Lever.

WARNING: IF YOUR LOCK HAS A PLASTIC INSERT ON THE OUTSIDE LEVER, IT MUST BE REPLACED WITH ONE OF THE TWO METAL INSERTS PROVIDED. These Inserts provide a metal-to-metal connection to make the Lock physically secure.

NOTE: Metal inserts are not available for Interchangeable Core (I.C.) Levers. The Schlage new style Driver with integral lug must be used with IC Levers.

FOR LEVERS HAVING PLASTIC INSERTS:

- Remove and discard the Plastic Insert.
- Insert the Key Cylinder into the Lever.
- Slide the Driver onto the Lock Spindle, fully engaging it in the Lock recess.
- Install the Metal Insert into the Driver. For SIX-PIN Key Cylinders, use the longer Metal Insert. For SEVEN-PIN Key Cylinders, use the shorter Metal Insert.
- Slide the Lever onto the Spindle until it makes contact with the Lever Catch. Do not attempt to force the Lever all the way on until the next step.
- Insert the Key into the Key Cylinder and rotate it clockwise at least 45°. Then, push the Lever the rest of the way on until the Lever Catch is engaged. Pull on the Lever to make sure the Lever Catch is engaged. **Turn the Key clockwise to set Lock in the unlocked condition and remove the Key from the Cylinder. The Lever cannot be rotated because it is locked by the QP2000.** For Series D53, D60, D73 and D80 Locks allow the Key to return to the horizontal position and remove it.

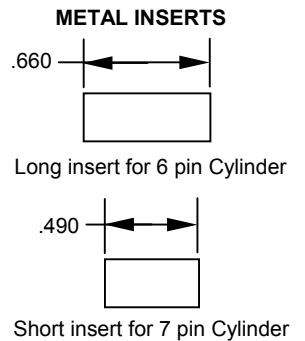

FOR LEVERS WITHOUT PLASTIC INSERTS:

- Place the Key Cylinder inside the Outside Lever.
- Insert the Driver into the Outside Lever.
- Partially insert the Key into the Cylinder and slide the Lever onto the Spindle until it stops against the Lever Catch.
- Insert the Key fully into the cylinder and, while pushing on the Lever, turn the Key (but not the lever) clockwise 45°. Push the Lever into place until the Lever Catch is engaged. Pull on the Lever to make sure the Lever Catch is engaged. **Turn the Key clockwise to set Lock in the unlocked condition and remove the Key from the Cylinder. The Lever cannot be rotated because it is locked by the QP2000.** For Series D53, D60, D73 and D80 Locks allow the Key to return to the horizontal position and remove it.

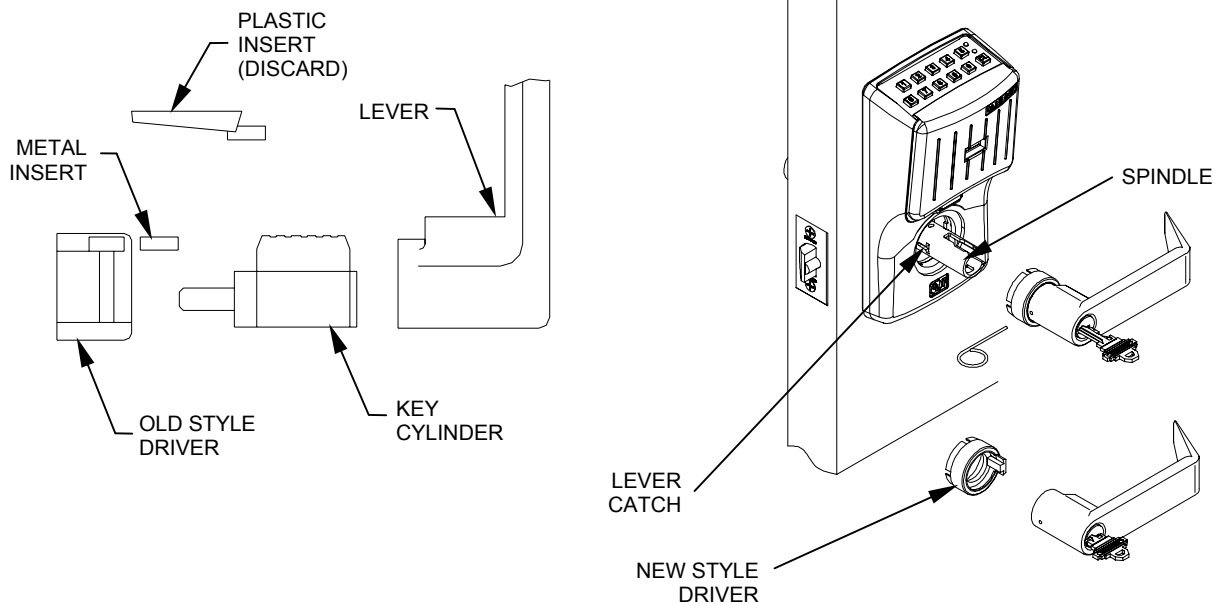

5-7 VERIFY PROPER OPERATION

- Verify proper operation of the System using the Default Programmer ID Proximity Card. Momentarily place the center of the Proximity Card (Included in the OMNILOCK Administrator's Kit) over the recess in the front of the QP2000. The QP2000 will flash green once and unlock, then, during the Open Delay Time, it will flash green five times. The QP2000 will flash red and lock. While unlocked, check for proper operation of the lock.
- If your System has a Keypad Proceed as follows, otherwise go to Section 5: Verify proper operation of the System using the Keypad. Enter the Default Programmer ID, **1 2 3 4**, at the Keypad. The Lights will flash as in the previous step.

SECTION 6: PROGRAM THE QP2000

IMPORTANT: To avoid unauthorized access, it is important to program a new Programmer I.D.

Refer to the OMNILOCK Administrator's Guide for programming instructions. If the Lock has been installed on a door before the required programming information is available, and the System has a Keypad, the Access Level may be set to Unlocked as follows:

- Enter the Default Manager ID, **2 2 2 2**, at the Keypad, the green light will flash.
- Press **2**, the green light will flash.
- Press and hold the **CL** key until the green light flashes four times. (The light will flash once when the CL key is first pressed, continue to hold the key until the light flashes three more times.)
- The Lock will remain in the Unlocked mode.

SECTION 7: REMOVAL OF LEVERS

7-1 REMOVING THE OUTSIDE LEVER

- Insert the Key into the Cylinder and turn it 45° clockwise.
- Depress the Lever Catch through the hole in the Outside Lever by using the Lever Removal Pin (provided with Schlage locks) or other suitable tool.
- Slide the Outside Lever from the Spindle.

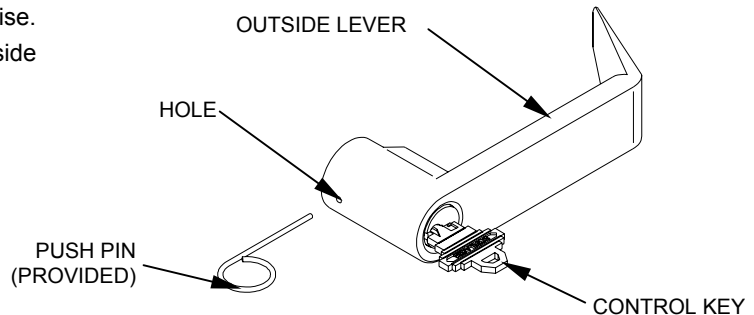

7-2 REMOVING THE INSIDE LEVER

- Depress the Lever Catch through the hole in the Inside Lever by using the Lever Removal Pin (provided with Schlage Locks) or other suitable tool.
- Slide the Inside Lever from the Spindle.

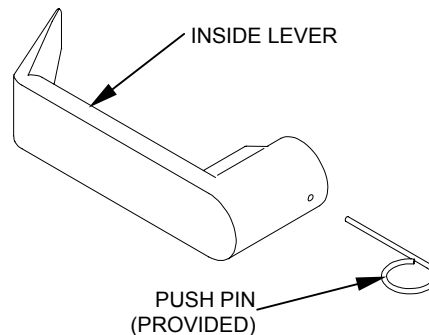

SECTION 8: INFORMATION FOR INSTALLERS

- Leave these instructions and other Documents with the User.
- Always verify the Lock is designed for the door thickness range in which it is to be installed. Locks can be purchased for a variety of door thickness through Schlage dealers.
- Retain any parts removed from the Lock during installation to allow restoration to original condition.